

BROMLEY CIVIC CENTRE, STOCKWELL CLOSE, BROMLEY BRI 3UH



THE LONDON BOROUGH
www.bromley.gov.uk

TELEPHONE: 020 8464 3333

CONTACT: Steve Wood
stephen.wood@bromley.gov.uk

DIRECT LINE: 020 8313 4316

DATE: 9 November 2023

To: Members of the
LICENSING SUB-COMMITTEE

Councillors Nicholas Bennett J.P., Melanie Stevens and Sam Webber

A meeting of the Licensing Sub-Committee will be held at Bromley Civic Centre, Stockwell Close, Bromley, BR1 3UH on **MONDAY 20 NOVEMBER 2023 AT 10.00 AM**

There will be a pre-meeting for Council Members and officers at 9.45am.

TASNIM SHAWKAT
Director of Corporate Services & Governance

A G E N D A

- 1 APPOINTMENT OF CHAIRMAN FOR THE MEETING**
- 2 DECLARATIONS OF INTEREST**
- 3 APPLICATION FOR A NEW PREMISES LICENCE AT LOPETO CAFE AT PRIORY GARDENS HIGH STREET ORPINGTON BR6 0HH
Orpington**
- 4 TEMPORARY EVENT NOTICE FOR FETHR LOUNGE LTD, 145 – 147 CROYDON ROAD, BECKENHAM, BR3 3RB FOR 30TH – 31ST DECEMBER 2023**

Objections to the applications are referred to in the attached reports of the Director of Environmental Services.

The Chairman will request the names and addresses of those giving evidence together with the names of any representatives.

This page is left intentionally blank

Report No.
ES20333

London Borough of Bromley

PART ONE - PUBLIC

Decision Maker: LICENSING SUB-COMMITTEE

Date: 20th November 2023

Decision Type: Non-Urgent Non-Executive Non-Key

Title: APPLICATION FOR A NEW PREMISES LICENCE AT
LOPETO CAFE AT PRIORY GARDENS HIGH STREET
ORPINGTON BR6 0HH

Contact Officer: Steve Phillips, Nuisance, ASB, Health & Safety and Licensing Manager
Tel: 020 8313 4659 E-mail: steve.phillips@bromley.gov.uk

Chief Officer: Colin Brand Director: Environment and Community Services

Ward: Orpington

1. Reason for report

- 1.1 To provide the Licensing Sub-Committee with information supporting them to determine this licence application.

2. **RECOMMENDATIONS**

- 2.1 The Licensing Sub-Committee asked to determine this application having taken into account the Council's Statement of Licensing Policy 2021 to 2026 and written and oral representations by the applicant and objectors.

Members can

1. Grant the licence
2. Grant the licence with the addition of conditions necessary to promote any of the licensing objectives
3. Exclude from the scope of the licence any of the licensable activities to which the application relates
4. Refuse to specify a person in the licence as the premises supervisor
5. Reject the application

Impact on Vulnerable Adults and Children

1. Summary of Impact:

When making decisions under the Licensing Act 2003 the Council is required to promote the licensing objectives, one of which is the protection of children from harm.

Corporate Policy

1. Policy Status: Existing Policy:

The Council has adopted a statement of its licensing policy under the Licensing Act 2003 for the period 2021 to 2026.

2. BBB Priority: Children and Young People Excellent Council Quality Environment Safe Bromley Vibrant, Thriving Town Centres Healthy Bromley Regeneration

Financial

1. Cost of proposal: Licensing statutes allow for an appeal to the Magistrates Court against the Council's decision. Should an appeal be made, costs are likely to be incurred but it is not possible to quantify these.
 2. Ongoing costs: Non-Recurring Cost
 3. Budget head/performance centre: Public Protection and Portfolio
 4. Total current budget for this head: £2.4M
 5. Source of funding: 2023/2024
-

Personnel

1. Number of staff (current and additional): 1 Licensing Officers supported by 3.5 FTE admin
 2. If from existing staff resources, number of staff hours: Not Applicable
-

Legal

1. Legal Requirement: Statutory Requirement: The Council is the Licensing Authority for the Licensing Act 2003. This is a Non-Executive function and is delegated to the General Purposes and Licensing Committee. Where representations are received about a licence application, it is referred to the Licensing Sub Committee for a hearing and decision.
 2. Call-in: Not Applicable
-

Procurement

1. Summary of Procurement Implications: Not applicable
-

Property

1. No property implications for this application/licence.
-

Carbon Reduction and Social Value

1. Summary of Carbon Reduction/Sustainability Implications: There are no significant implications.
-

Customer Impact

1. When considering and making a determination on this application Members need to balance the benefits of holding the licence against any adverse effects to the Public, Local Residents and Businesses by considering its impact against the licensing objectives
-

Ward Councillor Views

1. Have Ward Councillors been asked for comments? **Yes**. Ward Members were notified about the application by email on 30th August 2023.
 2. Summary of Ward Councillors' comments: **Comments** were received from Councillor Kim Botting on the grounds of Crime and Disorder regarding this application.
-

Responsible Authorities Views

1. Have Responsible Authorities been asked for comments? **Yes**. They were notified about the application by email on 30th August 2023.
 2. Summary of Responsible Authorities comments: **No objections** were received from Responsible Authorities. The Child Protection Team asked for a Challenge 25 policy condition to be added. The Police also contacted the applicant directly and asked for a number of conditions to be added to the licence as well as an earlier end time to the sale of alcohol of 21:30hrs.
-

Residents and interested parties

3 representations were received in support of the application and 31 valid representations were received from local residents objecting to the application.

These objections can be found in **Appendix 2**.

3. COMMENTARY

3.1. Licensing Act 2003.

The Licensing Act 2003 states that any premises requires a licence/certificate issued by the Council (premises licence/club premises certificate) where the following activities occur:-

Provision of regulated entertainment

- a) Plays. (Where the audience exceeds 500 people)
- b) Films.
- c) Indoor sporting events. (Where the audience exceeds 1000 people)
- d) Boxing or wrestling entertainment.
- e) Live music. (subject to the Live Music Act 2013 exemptions)
- f) Recorded music.
- g) Performances of dance. (Where the audience exceeds 500 people)

Provision of late-night refreshment (between 2300hrs and 0500hrs).

Supply of alcohol (on and off sales).

The supply of alcohol by or on behalf of a club to, or to the order of, a member of the club.

The sale by retail of alcohol by or on behalf of a club to a guest of a member of the club for consumption on the premises where the sale takes place.

Licences/Certificates may be issued subject to any terms, conditions or restrictions the Council feels are appropriate to address any or all of the four licensing objectives.

The Council has previously agreed Bromley's Statement of Licensing Policy for the Period 2021 – 2026.

The Licensing Sub-Committee must consider the Statement of Licensing Policy and any Special Policy of Cumulative Impact currently in force when making any decisions in respect of these applications.

Members' attention is drawn to the following parts of the policy which are relevant to this application.

Description of the Premises

Taken from the application form – "Lopeto is a cafe in the Priory Gardens which serves coffee, beverages and a range of sandwiches. It has 10 tables and 40 chairs and a bar for serving customers and also the front and back side of the cafe are available for dining and drinking. It also has an area for drink and food preparation."

A satellite image and street view of the premises can be found in **Appendix 4**.

Licensing History

This is an application for a new premises licence and the premises has not been licensed previously.

Details of the Application

This is an application for a new premises licence for the sale of alcohol From 11:00 to 22:00 every day. A full copy of the application form and plan can be found in **Appendix 1**.

Representations

During the public consultation period the Council received a total of 35 valid representations, 3 of which were in support of the application and 32 in objection to it. All of the valid representations can be found in **Appendix 2**.

4. IMPACT ON VULNERABLE ADULTS AND CHILDREN

- 4.1 Licensing regimes provide for additional controls through specific permissions to undertake activities. Both the Licensing Act 2003 and Gambling Act 2005 contain licensing objectives which seek to protect particular vulnerable groups. In the case of the Licensing Act 2003 it seeks to protect children from harm whereas the licensing objectives under the Gambling Act 2005 are wider and seek to protect children and vulnerable adults from being harmed or exploited.
- 4.2 Businesses and the Council are required to promote these objectives in the way they operate or make decisions.
- 4.3 Details of applications under both Acts are referred to the appropriate safeguarding teams for comment. The Child Protection Team asked for a Challenge 25 policy condition to be added.

5. TRANSFORMATION / POLICY IMPLICATIONS

- 5.1 Both the Licensing Act 2003 and the Gambling Act 2005 require the Council to prepare, consult on and publish statements of their licensing policy. These must be reviewed at least every 5 years under the Licensing Act and 3 years under the Gambling Act.
- 5.2 Members should make decisions in accordance with these policies but are free to depart from them with good reason.
- 5.3 The current policies are -
 - Statement of Licensing Policy 2021 - 2026
 - Statement of gambling policy 2022 - 2025

6. FINANCIAL IMPLICATIONS

- 6.1 There are rights of Judicial Review and appeal to the Magistrates Court against the decision of the Sub-Committee under both the Licensing and Gambling Acts. If an appeal were to be lodged there are costs associated with defending it. These are difficult to quantify and the Courts can award costs. In the event of a successful appeal we could pay the costs of the appellant as well as our own. Equally if we successfully defended an appeal, it is open to the Court to order our costs to be paid by the appellant.

7. PERSONNEL IMPLICATIONS

- 7.1 Number of staff (current and additional): 1 Licensing Officers supported by 3.5 FTE Administration Staff.

7.2 If from existing staff resources, number of staff hours: A licensing application typically takes 7hrs professional officer time and 5hrs administration time.

8. LEGAL IMPLICATIONS

8.1 Any Parties involved in a hearing before a Sub-Committee can seek a Judicial Review if the Local Authority has failed to administer the hearing in accordance with proper procedures.

8.2 Any Party involved with the hearing before licensing subcommittee can appeal any decision made at that hearing to the magistrate’s court.

8.3 The Council has adopted a procedure for the conduct of hearings.

9. PROCUREMENT IMPLICATIONS

There are no procurement implications.

10. PROPERTY IMPLICATIONS

There are no property implications.

11. CARBON REDUCTION/SOCIAL VALUE IMPLICATIONS

There are neutral environmental and carbon reduction implications from the proposals contained in this report.

12. CUSTOMER IMPACT

See para. 4 and 11 and Appendix 3 of this report.

13. WARD COUNCILLORS / OTHER STATUTORY CONSULTEES VIEWS

13.1 Have Ward Councillors been asked for comments? Yes. Ward Members were notified about the application by email on 30th August 2023.

13.2 Summary of Ward Councillors’ comments: Comments were received from Councillor Kim Botting on the grounds of Crime and Disorder regarding this application.

13.3 Responsible Authorities Views: 1 comment received from Responsible Authorities.

13.4 Summary of Responsible Authorities Views: Child Protection Team asked for a Challenge 25 policy condition to be added.

The following Responsible Authorities were notified about this application and their views sought.

Responsible Authority	Date Notified	Comments
Metropolitan Police	30th August 2023	No objection
Planning Authority	30th August 2023	No response
Trading Standards Service	30th August 2023	No response
Public Health Nuisance Team	30th August 2023	No response
Health & Safety Team	30th August 2023	No objection
Child Protection Team	30th August 2023	No objection if condition added
Fire Authority	30th August 2023	No objection
Public Health	30th August 2023	No response

Note: Whilst the police did not make any representations to the Licensing Authority, they did contact the applicant directly and requested that the hours were amended and a number of conditions be voluntarily added to the. The applicant agreed to these conditions and timings which can be found at **Appendix 3.**

Non-Applicable Sections:	Personnel and Procurement implications
Background Documents: (Access via Contact Officer)	Soft File Computer based records

Appendix 1

Application Form & Premises Plan

Application for a Premises Licence under the Licensing Act 2003

Please read the following instructions first –

- Use the Extra Page at the end of the form to provide further details if necessary
- When it is complete you can submit the form directly to us – click on the Submit Form button. You may wish to print and keep a copy of the completed form for your records. For help information about filling in this type of electronic form, click on the help information button
- [Please read the available information on the Licensing Act 2003](#)
- [Before completing this form please read the guidance notes](#)

What district/local area are you applying to?

I / We (premises licence holder name)

apply for a premises licence under section 17 of the Licensing Act 2003 for the premises described in Part 1 below (the premises) and I/we are making this application to you as the relevant licensing authority in accordance with section 12 of the Licensing Act 2003.

Part 1 – Premises Details

Postal address of premises or, if none, ordinance survey map reference or description

Postcode

Telephone number of premises

Non-domestic rateable value of premises
(if you are unsure, you can use this [Government link for more information](#))

Trading name of the business

Part 2 – Applicant Details

Please state whether you are applying for a premises licence as:

Please confirm:

I am carrying on or proposing to carry on a business which involves the use of the premises for licensable activities;

or

I am making the application pursuant to a:

Statutory function or

A function discharged by virtue of His Majesty's prerogative

INDIVIDUAL APPLICANTS (fill in as applicable)

Title

First names

Surname:

Are you 18 years or older? Yes No

Date of Birth

Current postal address if different from premises address

Postcode

Daytime contact telephone number

Email address

SECOND INDIVIDUAL APPLICANT (IF APPLICABLE)

Title

First names

Surname

Date of Birth (you must be 18 years old or over)

Current postal address if different from premises address

Postcode

Daytime contact telephone number

Email address

OTHER APPLICANTS

Please provide name and registered address of applicant in full. Where appropriate please give any registered number. In case of a partnership or other joint nature (other than a body corporate), please give the name and address of each party concerned.

Name

Be-Berry Ltd

Address

76 Crofton Road
Orpington
BR6 8HY

Registered number (where applicable)

12635178

Description of applicant (for example, partnership, company, unincorporated association etc.)

Limited Company

Telephone number (if any)

Email address (optional)

Operating Schedule

When do you want the premises licence to start?

If you wish the licence to be valid only for a limited period, when do you want it to end?

If 5,000 or more people attend the premises at any one time, please state the number expected to attend

General description of premises

Lopeto Is A Cafe At The Priory Gardens Which Serves Coffee Beverages
And A Range Of Sandwiches.
It Has 10 Tables And 40 Chairs And A Bar For Serving Customer And Also The Front And Back Side Of The Cafe Are Available For Dining And Drinking.
It Also Has A Area For Drink And Food Preparation.
Cctv Is Operating At The Premises.

Operating Schedule Continued

What licensable activities do you intend to carry on from the premises?

(Please see sections 1 of the Licensing Act 2003 and Schedule 1 and 2 to the Licensing Act)

Provision of regulated entertainment

- a) plays (if ticking yes, fill in box A)
- b) films (if ticking yes, fill in box B)
- c) indoor sporting events (if ticking yes, fill in box C)
- d) boxing or wrestling entertainment (if ticking yes, fill in box D)
- e) live music (if ticking yes, fill in box E)
- f) recorded music (if ticking yes, fill in box F)
- g) performance of dance (if ticking yes, fill in box G)
- h) anything of a similar description to that falling within (e), (f) or (g) (if ticking yes, fill in box H)
- i) **Provision of late night refreshment** (if ticking yes, fill in box I)
- j) **Supply of alcohol** (if ticking yes, fill in box J)

In all cases complete boxes K, L and M (on the following pages)

A

Plays Standard days and timings (please read guidance note 6)			Will the performance of a play take place indoors or outdoors or both? (please read guidance note 2)	Indoors	<input type="checkbox"/>
				Outdoors	<input type="checkbox"/>
				Both	<input type="checkbox"/>
Day	Start time	Finish time	Please give further details here (please read guidance note 3)		
Mon	<input type="text"/>	<input type="text"/>			
	<input type="text"/>	<input type="text"/>			
Tues	<input type="text"/>	<input type="text"/>			
	<input type="text"/>	<input type="text"/>			
Wed	<input type="text"/>	<input type="text"/>	State any seasonal variations for performing plays (please read guidance note 4)		
	<input type="text"/>	<input type="text"/>			
Thur	<input type="text"/>	<input type="text"/>			
	<input type="text"/>	<input type="text"/>			
Fri	<input type="text"/>	<input type="text"/>			
	<input type="text"/>	<input type="text"/>			
Sat	<input type="text"/>	<input type="text"/>			
	<input type="text"/>	<input type="text"/>			
Sun	<input type="text"/>	<input type="text"/>			
	<input type="text"/>	<input type="text"/>			

B

Films Standard days and timings (please read guidance note 6)			Will the exhibition of films take place indoors or outdoors or both? (please read guidance note 2)	Indoors <input type="checkbox"/>		
				Outdoors <input type="checkbox"/>		
				Both <input type="checkbox"/>		
Day	Start time	Finish time	Please give further details here (please read guidance note 3)			
Mon	<input type="text"/>	<input type="text"/>				
	<input type="text"/>	<input type="text"/>				
Tues	<input type="text"/>	<input type="text"/>				
	<input type="text"/>	<input type="text"/>				
Wed	<input type="text"/>	<input type="text"/>			State any seasonal variations for the exhibition of films (please read guidance note 4)	
	<input type="text"/>	<input type="text"/>				
Thur	<input type="text"/>	<input type="text"/>				
	<input type="text"/>	<input type="text"/>				
Fri	<input type="text"/>	<input type="text"/>	Non standard timings. Where you intend to use the premises for the exhibition of films at different times than those listed, please list (please read guidance note 5)			
	<input type="text"/>	<input type="text"/>				
Sat	<input type="text"/>	<input type="text"/>				
	<input type="text"/>	<input type="text"/>				
Sun	<input type="text"/>	<input type="text"/>				
	<input type="text"/>	<input type="text"/>				

C

Indoor Sporting Events Standard days and timings (please read guidance note 6)				
Day	Start time	Finish time	Please give further details here (please read guidance note 3)	
Mon	<input type="text"/>	<input type="text"/>		
	<input type="text"/>	<input type="text"/>		
Tues	<input type="text"/>	<input type="text"/>		
	<input type="text"/>	<input type="text"/>		
Wed	<input type="text"/>	<input type="text"/>	State any seasonal variations for indoor sporting events (please read guidance note 4)	
	<input type="text"/>	<input type="text"/>		
Thur	<input type="text"/>	<input type="text"/>		
	<input type="text"/>	<input type="text"/>		
Fri	<input type="text"/>	<input type="text"/>		Non standard timings. Where you intend to use the premises for indoor sporting events at different times than those listed, please list (please read guidance note 5)
	<input type="text"/>	<input type="text"/>		
Sat	<input type="text"/>	<input type="text"/>		
	<input type="text"/>	<input type="text"/>		
Sun	<input type="text"/>	<input type="text"/>		
	<input type="text"/>	<input type="text"/>		

D

Boxing or wrestling entertainment Standard days and timings (please read guidance note 6)			Will the boxing or wrestling entertainment take place indoors or outdoors or both? (please read guidance note 2)	Indoors <input type="checkbox"/>				
				Outdoors <input type="checkbox"/>				
				Both <input type="checkbox"/>				
Day	Start time	Finish time	Please give further details here (please read guidance note 3)					
Mon	<input type="text"/>	<input type="text"/>						
	<input type="text"/>	<input type="text"/>						
Tues	<input type="text"/>	<input type="text"/>						
	<input type="text"/>	<input type="text"/>						
Wed	<input type="text"/>	<input type="text"/>				State any seasonal variations for boxing or wrestling entertainment (please read guidance note 4)		
	<input type="text"/>	<input type="text"/>						
Thur	<input type="text"/>	<input type="text"/>						
	<input type="text"/>	<input type="text"/>						
Fri	<input type="text"/>	<input type="text"/>	Non standard timings. Where you intend to use the premises for boxing or wrestling entertainment at different times than those listed, please list (please read guidance note 5)					
	<input type="text"/>	<input type="text"/>						
Sat	<input type="text"/>	<input type="text"/>						
	<input type="text"/>	<input type="text"/>						
Sun	<input type="text"/>	<input type="text"/>						
	<input type="text"/>	<input type="text"/>						

E

Live music Standard days and timings (please read guidance note 6)			Will the performance of live music take place indoors or outdoors or both? (please read guidance note 2)		Indoors	<input type="checkbox"/>		
					Outdoors	<input type="checkbox"/>		
					Both	<input type="checkbox"/>		
Day	Start time	Finish time	Please give further details here (please read guidance note 3)					
Mon	<input type="text"/>	<input type="text"/>	State any seasonal variations for performance of live music (please read guidance note 4)					
	<input type="text"/>	<input type="text"/>						
Tues	<input type="text"/>	<input type="text"/>						
	<input type="text"/>	<input type="text"/>						
Wed	<input type="text"/>	<input type="text"/>						
	<input type="text"/>	<input type="text"/>						
Thur	<input type="text"/>	<input type="text"/>						
	<input type="text"/>	<input type="text"/>						
Fri	<input type="text"/>	<input type="text"/>					Non standard timings. Where you intend to use the premises for the performance of live music at different times than those listed, please list (please read guidance note 5)	
	<input type="text"/>	<input type="text"/>						
Sat	<input type="text"/>	<input type="text"/>						
	<input type="text"/>	<input type="text"/>						
Sun	<input type="text"/>	<input type="text"/>						
	<input type="text"/>	<input type="text"/>						

F

Recorded music Standard days and timings (please read guidance note 6)			Will the playing of recorded music take place indoors or outdoors or both? (please read guidance note 2)	Indoors	<input type="checkbox"/>
				Outdoors	<input type="checkbox"/>
				Both	<input type="checkbox"/>
Day	Start time	Finish time	Please give further details here (please read guidance note 3)		
Mon	<input type="text"/>	<input type="text"/>			
	<input type="text"/>	<input type="text"/>			
Tues	<input type="text"/>	<input type="text"/>			
	<input type="text"/>	<input type="text"/>			
Wed	<input type="text"/>	<input type="text"/>	State any seasonal variations for playing recorded music (please read guidance note 4)		
	<input type="text"/>	<input type="text"/>			
Thur	<input type="text"/>	<input type="text"/>			
	<input type="text"/>	<input type="text"/>			
Fri	<input type="text"/>	<input type="text"/>			
	<input type="text"/>	<input type="text"/>			
Sat	<input type="text"/>	<input type="text"/>			
	<input type="text"/>	<input type="text"/>			
Sun	<input type="text"/>	<input type="text"/>			
	<input type="text"/>	<input type="text"/>			

G

Performance of dance Standard days and timings (please read guidance note 6)			Will the performance of dance take place indoors or outdoors or both? (please read guidance note 2)	Indoors	<input type="checkbox"/>
				Outdoors	<input type="checkbox"/>
				Both	<input type="checkbox"/>
Day	Start time	Finish time	Please give further details here (please read guidance note 3)		
Mon	<input type="text"/>	<input type="text"/>			
	<input type="text"/>	<input type="text"/>			
Tues	<input type="text"/>	<input type="text"/>			
	<input type="text"/>	<input type="text"/>			
Wed	<input type="text"/>	<input type="text"/>	State any seasonal variations for the performance of dance (please read guidance note 4)		
	<input type="text"/>	<input type="text"/>			
Thur	<input type="text"/>	<input type="text"/>			
	<input type="text"/>	<input type="text"/>			
Fri	<input type="text"/>	<input type="text"/>			
	<input type="text"/>	<input type="text"/>			
Sat	<input type="text"/>	<input type="text"/>			
	<input type="text"/>	<input type="text"/>			
Sun	<input type="text"/>	<input type="text"/>			
	<input type="text"/>	<input type="text"/>			

H

<p>Anything of a similar description to that falling within (e), (f) or (g) Standard days and timings (please read guidance note 6)</p>			<p>Please give a description of the type of entertainment you will be providing</p> <div style="border: 1px solid black; height: 80px; width: 100%;"></div>			
			<p>Will the entertainment take place indoors or outdoors or both? (please read guidance note 2)</p>		Indoors	<input type="checkbox"/>
					Outdoors	<input type="checkbox"/>
					Both	<input type="checkbox"/>
Day	Start time	Finish time	Please give further details here (please read guidance note 3)			
Mon	<input type="text"/>	<input type="text"/>	<p>Please give further details here (please read guidance note 3)</p>			
	<input type="text"/>	<input type="text"/>				
Tues	<input type="text"/>	<input type="text"/>				
	<input type="text"/>	<input type="text"/>				
Wed	<input type="text"/>	<input type="text"/>				
	<input type="text"/>	<input type="text"/>				
Thur	<input type="text"/>	<input type="text"/>				
	<input type="text"/>	<input type="text"/>				
Fri	<input type="text"/>	<input type="text"/>				
	<input type="text"/>	<input type="text"/>				
Sat	<input type="text"/>	<input type="text"/>				
	<input type="text"/>	<input type="text"/>				
Sun	<input type="text"/>	<input type="text"/>				
	<input type="text"/>	<input type="text"/>				

State any seasonal variations for entertainment of a similar description to that falling within (e), (f) and (g) (please read guidance note 4)

Non standard timings. Where you intend to use the premises for entertainment of a similar description to that falling within (e), (f) or (g) at different times than those listed, please list (please read guidance note 5)

I

Late night refreshment Standard days and timings (please read guidance note 6)			Will the provision of late night refreshment take place indoors or outdoors or both? (please read guidance note 2)	Indoors <input type="checkbox"/>				
				Outdoors <input type="checkbox"/>				
				Both <input type="checkbox"/>				
Day	Start time	Finish time	Please give further details here (please read guidance note 3)					
Mon	<input type="text"/>	<input type="text"/>						
	<input type="text"/>	<input type="text"/>						
Tues	<input type="text"/>	<input type="text"/>						
	<input type="text"/>	<input type="text"/>						
Wed	<input type="text"/>	<input type="text"/>				State any seasonal variations for the provision of late night refreshment (please read guidance note 4)		
	<input type="text"/>	<input type="text"/>						
Thur	<input type="text"/>	<input type="text"/>						
	<input type="text"/>	<input type="text"/>						
Fri	<input type="text"/>	<input type="text"/>	Non standard timings. Where you intend to use the premises for the provision of late night refreshment at different times than those listed, please list (please read guidance note 5)					
	<input type="text"/>	<input type="text"/>						
Sat	<input type="text"/>	<input type="text"/>						
	<input type="text"/>	<input type="text"/>						
Sun	<input type="text"/>	<input type="text"/>						
	<input type="text"/>	<input type="text"/>						

J

Supply of alcohol Standard days and timings (please read guidance note 6)			Will the supply of alcohol be for consumption: (please read guidance note 2)	On the premises <input type="checkbox"/>		
				Off the premises <input type="checkbox"/>		
				Both <input checked="" type="checkbox"/>		
Day	Start time	Finish time	State any seasonal variations for the supply of alcohol (please read guidance note 4)			
Mon	<input type="text" value="11:00"/>	<input type="text" value="22:00"/>				
	<input type="text"/>	<input type="text"/>				
Tues	<input type="text" value="11:00"/>	<input type="text" value="22:00"/>				
	<input type="text"/>	<input type="text"/>				
Wed	<input type="text" value="11:00"/>	<input type="text" value="22:00"/>				
	<input type="text"/>	<input type="text"/>				
Thur	<input type="text" value="11:00"/>	<input type="text" value="22:00"/>			Non standard timings. Where you intend to use the premises for the supply of alcohol at different times than those listed, please list (please read guidance note 5)	
	<input type="text"/>	<input type="text"/>				
Fri	<input type="text" value="11:00"/>	<input type="text" value="22:00"/>				
	<input type="text"/>	<input type="text"/>				
Sat	<input type="text" value="11:00"/>	<input type="text" value="22:00"/>				
	<input type="text"/>	<input type="text"/>				
Sun	<input type="text" value="11:00"/>	<input type="text" value="22:00"/>				
	<input type="text"/>	<input type="text"/>				

State the name and details of the individual whom you wish to specify on the licence as Designated Premises Supervisor (DPS).

Title	<input type="text"/>
First Name(s)	<input type="text"/>
Surname	<input type="text"/>
Date of Birth	<input type="text"/>
Address	<input type="text"/>
Postcode	<input type="text"/>
Personal licence number	<input type="text"/>
Issuing licensing authority	<input type="text"/>

Please print the 'Consent of individual to being specified as premises supervisor' form and have the person specified above sign and confirm the details given.

K

Please highlight any adult entertainment or services, activities, other entertainment or matters ancillary to the use of the premises that may give rise to concern in respect of children (please read guidance note 8)

L

Hours premises are open to the public Standard days and timings (please read guidance note 6)			State any seasonal variations (please read guidance note 4)	
Day	Start time	Finish time		
Mon	<input type="text" value="08:00"/>	<input type="text" value="22:00"/>		
Tues	<input type="text" value="08:00"/>	<input type="text" value="22:00"/>		
Wed	<input type="text" value="08:00"/>	<input type="text" value="22:00"/>		
Thur	<input type="text" value="08:00"/>	<input type="text" value="22:00"/>		Non standard timings. Where you intend to use the premises to be open to the public at different times than those listed, please list (please read guidance note 5)
Fri	<input type="text" value="08:00"/>	<input type="text" value="22:00"/>		
Sat	<input type="text" value="08:00"/>	<input type="text" value="22:00"/>		
Sun	<input type="text" value="08:00"/>	<input type="text" value="22:00"/>		

a) General – all four licensing objectives (b,c,d,e) (please read guidance note 9)

I will make sure at all time that selling of alcohol is done in our premises, there are sufficient, trained, well prepared staff that are aware of licencing objectives and know how to deal with drunk people and prevent crime and disorder. I will provide adequate training for the staff.
Also the rules and conditions of selling alcohol specially prohibition of sale to underage customers will be strictly followed.

b) The prevention of crime and disorder

Staff are awar and trained that any sort of crime and prohibited activities to be reported to the police immediately. The premises is equipped with cameras that cover all doors, floor area and food preparation segment and till area. Any person in the premises will be fully captured by one of the cameras (from foot to head). Also floor cameras capture wide angle so any incident is visible and makes it easy to investigate the incident. Also date and time are recorded and the videos are saved for 30 days.

c) Public safety

1. Premises electric wiring is always investigated to prevent any incident
2. All appliances, fridges, microvawes, coffe machine, grill, etc are serviced regularly as well to avoid any hazard.
3. Fire safety equipments including fire extinguisher, fire blanket and smoke detectors are available and installed in the premises.
4. Doors are open and free from obstruction at all time.

d) The prevention of public nuisance

1. Music tune is always controlled to not disturb surrounding area.
2. Customers are instructed and asked to leave the premises quietly.
3. The premises is located at the corner of Priory garden and there is no residential property in immediate surrounding.
4. There are some tables in the garden but customers will be asked to chat quietly and not make loud noise.

e) The protection of children from harm

1. Customers that appear to be underage will be asked for proof of ID before selling any alcoholic drink.
2. All staff will be trained about prohibition of sale to underage customers.
3. A register of refused sales will be kept and maintained on the premises all the time for reference.

Custom Process Configuration

XML Specific

Application type	<input type="text"/>
Licence Case Type	<input type="text"/>
Licence Status	<input type="text"/>
XML Template	<input type="text"/>
CAPS Reference	<input type="text"/>

Payments request

CallingAppID	<input type="text"/>
CallingAppRef	<input type="text"/>
PaymentSourceCode	<input type="text"/>

Response response

PaymentAuthorisationCode	<input type="text"/>
IncomeManagementReceiptNumber	042-9444
Originators Reference	<input type="text"/>
CardScheme	<input type="text"/>
CardType	<input type="text"/>
PaymentAmount	<input type="text"/>
ResponseCode	<input type="text"/>
ResponseDescription	SUCCESS
Number of payment lines	<input type="text"/>

Payment 1

Receipt Number	<input type="text"/>
DueDate	<input type="text"/>
PaymentType	<input type="text"/>
Pay Description	<input type="text"/>
XML Description	Premises Licence
PaymentDue	£190.00
Paid	<input type="text"/>
Payment Date	26/08/2023
Fund	<input type="text"/>
Reference	YF2NDB10N98

Form Calculations

Title Casing	<input type="text"/>
Sentence Casing	<input type="text"/>
UPRN for address lookup	<input type="text"/>
Boolean to hide this page	<input type="checkbox"/> <input type="checkbox"/>
Field for email (Bath or Brom)	Brom
Field for fee array	BandA,100.00,BandB,190.00,BandC,315.00,BandDNoAlcohol,450.00,BandDAlcohol,450.00,BandENoAlcohol,635.00,BandEAlcohol,635.00
WRS custodian initials	<input type="text"/>

Other Custom Calculations

Calculation for licensable activities	<input type="text"/>	App Day Tel	<input type="text"/>
Subject Line for Email Out	<input type="text"/>	App Email	<input type="text"/>
Body for Internal Email	<input type="text"/>	App Address	<input type="text"/>
Body for External Email	<input type="text"/>	App DOB	<input type="text"/>
Start Date in XML format	<input type="text"/>	App 2 D Tel	<input type="text"/>
End Date in XML Format	<input type="text"/>	App 2 Email	<input type="text"/>
Hours the TEN covers	<input type="text"/>	App 2 Add	<input type="text"/>
DOB	<input type="text"/>	App 2 DOB	<input type="text"/>
Customer Email Acknowledgment	<input type="text"/>	Agent D Tel	<input type="text"/>
Premise Activities Complete	<input type="text"/>	Agent Add	<input type="text"/>
Premise Activities Part 1	<input type="text"/>	Agent Email	<input type="text"/>
Premise Activities Part 2	<input type="text"/>	Open Hours	<input type="text"/>
Premise Address	<input type="text"/>	App 3 D Tel	<input type="text"/>
TP Address	<input type="text"/>	App 3 Email	<input type="text"/>
TP DOB	<input type="text"/>	Ext Pty Email	<input type="text"/>

I will provide the plan of the premises (See [section 2.9](#) of this guidance)

I will provide the consent form

I understand I must now advertise my application

I understand that if I do not comply with the above requirements my application will be rejected

I am applying as an individual rather than a business / limited company and have provided proof of my entitlement to work in the UK (for information on what you can provide as evidence, [please reference our evidence guidance notes](#))

Please attach evidence using the 'Upload & Attach Files' button.

Types of files accepted as attachments: gif, jpg, jpeg, tif, tiff, bmp, png and pdf.

Please ensure that the documents you attach are complete and easy to read. If documents are incomplete or are difficult to read this may result in a delay in your application.

Declaration (please read guidance note 10)

[Applicable to individual applicants only, including those in a partnership which is not a limited liability partnership] I understand I am not entitled to be issued with a licence if I do not have the entitlement to live and work in the UK (or if I am subject to a condition preventing me from doing work relating to the carrying on of a licensable activity) and that my licence will become invalid if I cease to be entitled to live and work in the UK.

The DPS named in this application form is entitled to work in the UK (and is not subject to conditions preventing him or her from doing work relating to a licensable activity) and I have seen a copy of his or her proof of entitlement to work, if appropriate.

Confirmation of applicant or applicant’s solicitor or other duly authorised agent. (See guidance note 11) **If confirming on behalf of the applicant please state in what capacity.**

Confirmation

Name

Danielnabi Ebadi

Date

31/05/2023

Capacity (owner, director etc.)

Director

For joint applications confirmation of 2nd applicant or 2nd applicant’s solicitor or other authorised agent (please read guidance note 12) **If confirming on behalf of the applicant please state in what capacity.**

Confirmation

Name

Date

Capacity (owner, director etc.)

Contact name (where not previously given) and postal address for correspondence associated with this application (please read guidance note 13)

Name

Address

Postcode

Telephone number (if any)

If you would prefer us to correspond with you by email, your email address (optional)

Use this page if there is any other information that you think we should know about.
Information entered on this page will be sent to us, along with the data on the rest of the form when you use the "Submit" option.

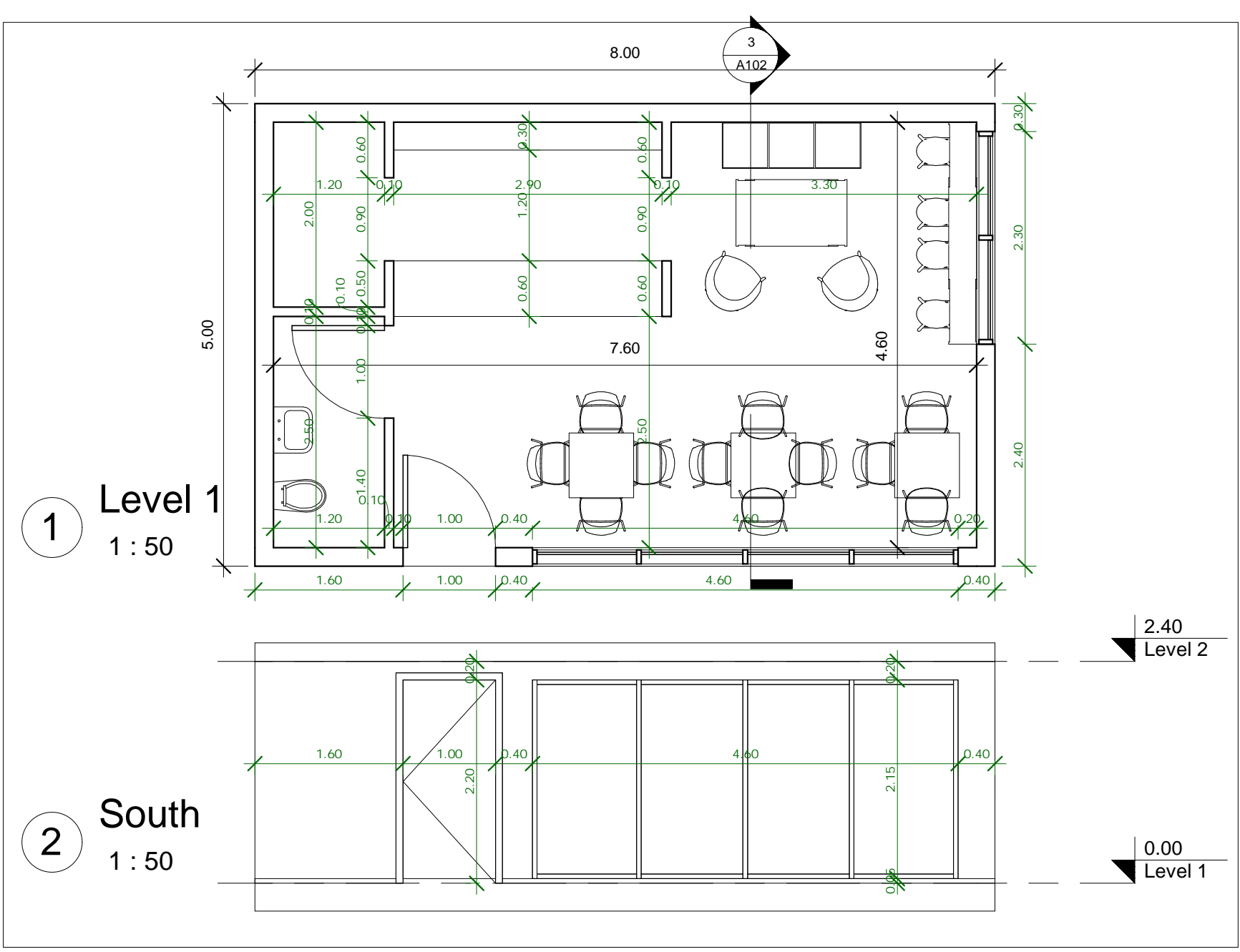

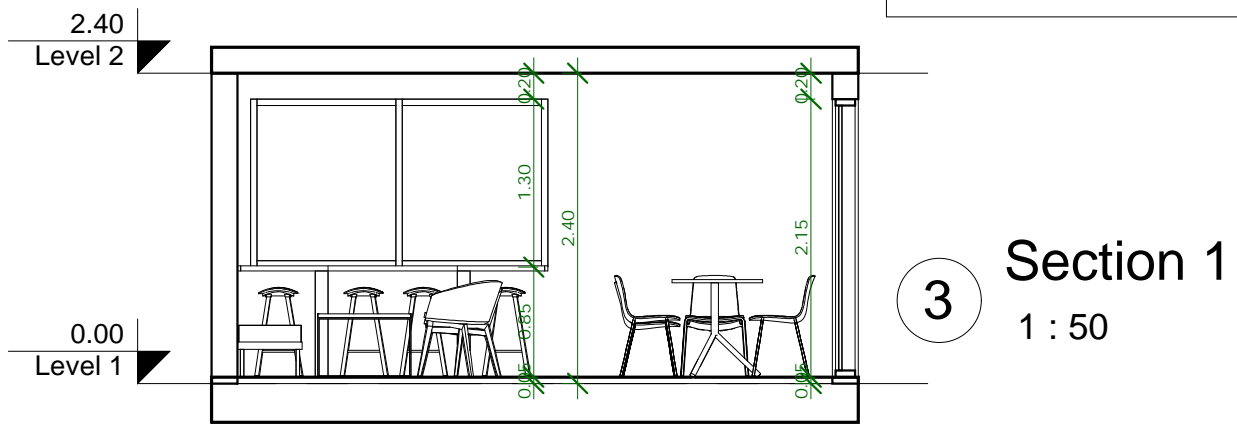
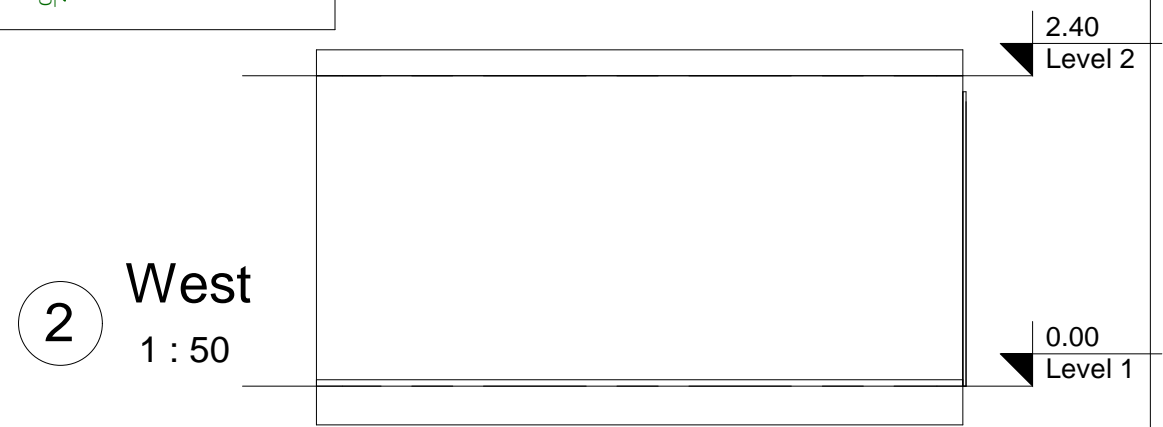
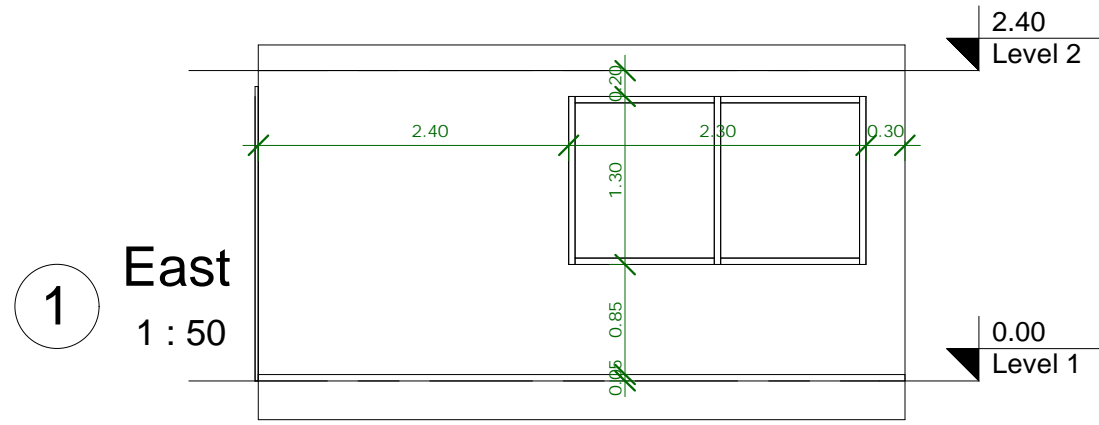

Appendix 2

Representations

Application comments:

OBJECTIONS

Objection 1. This is definitely not the correct place to grant an alcohol license or extended opening times. There is already too much anti-social behaviour in this area of our town, don't make it worse!

Objection 2. I would like to strongly object to the cafe obtaining a licence to serve alcohol. Priory Gardens is a known area for anti social behaviour and I do not believe serving alcohol there will help matters. There are many wild animals and birds which may well be disturbed by the sounds of people drinking alcohol, especially rowdy behaviour outside at night. I would advise the Council to liaise with the Police to get their view. Additionally, if the cafe operates a takeaway business when the park is officially closed, children and young adults will have access to the park. There have been numerous attacks on wildlife by youngsters. Again, the Police should be consulted on this point. I hope the Council will take a sensible view and not grant this application

Objection 3. I would like to object to this application on the grounds that it is not a suitable venue to be open until 10pm and with an alcohol licence. There is already a problem within this park with antisocial behaviour and teenagers catapulting the ducks in the pond. This is unacceptable and there should be a police presence in that park and it should be locked at night, certainly not with a late night takeaway and alcohol.

Also Priory gardens is a conservation area so this sort of application is unsuitable, it also has homes nearby who will suffer from late night activity. And as there is no local pub in the high street any more certain people could use the cafe as a late night drinking establishment. Totally inappropriate for the park and should be rejected.

Objection 4. PM This is a lovely cafe that services people that spend time visiting the park, in particular to spend time feeding the wildlife there.

As you are aware there have been a lot of issues recently with police being called to the park to deal with anti social behaviour towards the wildlife by teenagers using catapults. Regular police patrols are carried out a daily basis, to increase their visibility within the park.

Ward security also attend to do patrols and are also responsible for locking the park gates every night. The cafe has a rear entrance that leads into the park, which would obviously cause an issue in securing the park at night by Ward `Security.

Safety of the staff working there in the evening would be of concern,

and having cash/alcohol on the property would leave the staff in a vulnerable position.

I cannot foresee where their trade would come from to justify them increasing their opening hours to facilitate the sale of alcohol!

Objection 5. Granting a licence to the cafe would cause more anti social behaviour, the gardens have a no alcohol policy and the cafe has a entrance in the park, the amount of litter of beer cans will increase ,also the 10pm closing time would be to late for ward security to shut the park safely families enjoy the park and do not wish to see unruly people in the park , there is enough anti social behaviour already with wild life

Application comments:

being attacked using catapults and nuts bought locally, the police have enough on there plates and this will be another problem for them to deal with

Objection 6. I use this cafe on a regular basis, when attending the park to take pictures of the wildlife there. Lots of families go there to feed the ducks and use the playground area.

There have recently been attacks on the wildlife causing injuries and on a number of occasions birds have been rescued from the park and taken to the swan sanctuary. Police have also been called numerous times to deal with kids using catapults on the birds. I was there on one occasions and heard the noises caused by the nuts being fired from the catapults, causing real distress to the birds there.

If the cafe was to stay open late and serve alcohol, this would surely have an impact on when the park would be locked by Ward Security. The birds are vulnerable at the moment, and volunteers patrol the park in the evenings to try and safeguard them.

I cannot see an increase in trade for the cafe if they stay open later and sell alcohol. I feel this will lead to further anti social behaviour which the police will have to deal.

Objection 7. I live directly opposite Priory Gardens so see a lot of anti social behaviour taking place in the park, especially when the gates are locked each evening. This extension goes against the park being locked as there will be access to the park. The cafe is lovely but is quite small and I cannot see the staff being able to stop any people from walking out of their park facing door once the other gates are closed.

Objection 8. I object to a licence to sell alcohol being granted. Priory Gardens already experiences a great deal of anti social behaviour which includes but is not limited to wildlife being subject to injury by primarily a small number of local youths. Members of the public give their time for free to patrol the park to prevent injury to wildlife and other anti social behaviour. Currently the park is closed half hour after dusk but should the cafe be granted an alcohol licence it will be closing much later allowing further opportunities for harm to wildlife and anti social behaviour. Orpington Town Centre is an area that is defined as lacking in green space. I would not want this valuable asset to be further compromised. I appreciate the owner of the premises has stated how he will manage his premise should he be granted a licence but how will he safeguard the wildlife and park in general. The police are fully aware of the scale of anti social behaviour in the park and they do not have the resources to address this problem without allowing for extended periods of time the park is open. I would ask Bromley to reject this change in use.

Objection 9. There is already a problem in this area with people drinking and anti social behaviour. This will add to the issues

Objection 10. There are already many street drinkers around the area and a park next door which would likely see an increase in not only anti social behaviour but possible assault a etc. I can't see any benefit to this at all. There is a child's playground in the park and would not feel great about intoxicated people in this environment.

Objection 11. The area is unsafe enough without including the sale of alcohol. There would be further damage and degradation to the already fragile area.

Application comments:

The wildlife in the immediate area(near the pond) would be impacted being disturbed in the evening.

Objection 12. The level of antisocial behaviour and cruelty to wildlife in the park is already dreadful. This would only make it worse. If this business wants to change to a licensed premises perhaps they could move to a more suited location in one of the many empty premises in the High St.

Objection 13. Absolutely NO! That area is rife with drug addicts alcoholics and beggars. The care has established a beautiful little corner of the park where families can relax and enjoy the park at all times of the day.

Introducing alcohol into the equation would radically change what Orpington residents value to a seedy little addition to Carlton parade where the beggars and drug addicts congregate. It would make shopping at Carlton parade Co-op and Twins chip shop in the evening a scarier prospect than it already is. DEFINITELY NO!!!

Objection 14. Just what Orpington needs, drinking till 10 and let loose on the high street ! Do you not think we have enough anti social problems at it. This is madness

Objection 15. There has been a lot of ASB at the Priory and the police have been called many times and some of those calls were people drunk in the Priory gardens. I consider selling Alcohol on and off the premises would lead to further ASB and it would be a public nuisance and put park goers safety at risk. The police have a duty to prevent crime and disorder, how can they be expected to monitor people's behaviour in the cafe having consumed Alcohol. There is constant trouble at the nearby bus stop , I can imagine there will be more unruly behaviour if people are under the influence of Alcohol.

Ward Security have a duty to lock the Park securely at 9pm Summer time and in the Winter earlier depending on the daylight hours. How can they securely lock up if the cafe doors are open and possibly the gates by the cafe. Anyone can walk through.

Alcohol is not permitted in the park, so how can they sell alcohol on park premises and surrounding area?.

Will the staff be properly trained in selling Alcohol?. I have seen them mistake what people have ordered, serving up the wrong drink and having to take it back and correct their error.

There will be bottles, cans , glasses around that can be thrown into the ponds endangering the waterfowl. At present the cafe does not have its own bin, only a Council one outside.

Although the application says there are no residential property in immediate surroundings. What about the flats opposite and not far away houses by the bus stop.

Teenagers already steal Alcohol from nearby shops, they can easily steal from the cafe and take it into the park.

I urge the Council to take all objections into consideration before granting a license for Lopetos selling Alcohol . I note that the application says they want the license to start

Application comments:

from the 11th September 2023. For some reason the postcode on the application does not match the one of the notice on their door.

Objection 16. Local residents are already woke up at all hours by people visiting the garage. I can't remember the last time I wasn't woken up during the night. We do not need more reasons for people to be hanging around the area. Furthermore the park is closed at that time of the night so customers would be standing around the narrow path on the road side of the cafe. This would be intimidating to people trying to pass by. There is a lot of anti social behavior already in Carlton Parade we don't need to add another aspect to this.

Objection 17. This application will attract people that may be unsafe to the local wildlife population especially late at night. It will disturb biodiversity and the ponds will potential litter. Furthermore packaging used for takeaways may contain microplastics and other harmful chemicals. As well as this there are lots of late night takeaway shops around the local area already and this one is not necessary.

Objection 18. I feel that this is a very bad idea; likely to lead to (further) anti-social behaviour .

Objection 19. The café is small and by all accounts doing very well as an appropriate park café. The park (listed asset) is a wonderful community asset and a haven for our children, families and the elderly. It is a safe, pleasant and healthy place to be. Serving alcohol at such a tiny cafe spilling into the outdoor area, is not a good idea at all. I can only see drawbacks. This will inevitably lead to alcohol consumption in the park at large. There are plenty of empty units on the high street appropriate for cafe/bar. This premises s not a suitable location for this project. I therefore strongly object.

Objection 20. PM Priory gardens is a family space and there are already challenges with alcohol consumption and asb.

Adjusting the establishment to provide alcohol will further the problem

Objection 21. There are already numerous places to purchase alcohol in the High Street. Selling alcohol will encourage even more anti social behaviour than there is at the present time. It's too near the park and wildlife.

Objection 22. This place is an amazing cafe, child friendly in a park with beautiful wildlife and does not need alcohol. Opening until 10pm and serving alcohol sounds like it would be asking for a lot of antisocial behaviour. There are plenty of other places to sit and have a drink and socialise but a park is not one of those

Objection 23. I object to this planning application due to the phenomenal amount of ASB in Priory Gardens. Alcohol would have to be stored on the premises and could be stolen. Alcohol consumption on and off of the premises could cause intoxication and could add to the levels of ASB in Priory Gardens and surrounding area when they leave. They could buy alcohol to drink in park. We have wildlife in Priory Gardens that have been targeted by people with catapults and we cannot risk any more harm being done to them especially if people are drinking on tables by the pond. Gates to Priory Gardens usually close at dusk but would have to stay open to allow cafe visitors to leave. Bottles could litter the ponds and park and noise levels could disturb

Application comments:

neighbours. Priory Gardens is a high crime area at best and alcohol being sold in the park could exacerbate the crime levels against the wildlife and other people. There are notices prohibiting the consumption of alcohol in the park. There would be no security to control ASB, and workers in the cafe have already made mistakes on prices and drinks being sold to me so might not be on the ball to monitor underage buying.

Objection 24. I wish to object strongly to this application by Priory Gardens Cafe.

It is totally inappropriate to sell alcohol where children are around.

Objection 25. I am totally against this. Young families and young children go to the park here and there are ducks, geese and swans in the park which unfortunately are all ready being hurt/ killed.

We don't need people sitting here drinking alcohol. The cafe is lovely as it is and should be left like this.

Objection 26. I wish to lodge a strong objection to this application for an alcohol licence for the café in Priory Gardens, Orpington. This is a public park frequented by families and children of all ages. An alcohol licence for the café would change the whole atmosphere of the park and encourage young people to drink alcohol.

Objection 27. I really feel it would attract an element to the park that is unnecessary. Alcohol and an open park space, with open water areas, is just asking for trouble and poses a potential risk to life!

Surely there are sufficient licensed vendors in the area to negate the need for a such a tiny premises to be granted a licence. I also feel that, in such small premises there will be a greater risk of vandalism to steal stock. Also greater chance of vandalism by inebriated persons in the park.

I strongly recommend that this application for an alcohol licence be declined.

Objection 28. Alcohol in the Park, really?

Obviously there are other places around where people can buy alcohol so this isn't essential. Tea, coffee and soft drinks would suffice. Some cafés serve a light lager with food but it would need to be with a proper meal and not just with a burger or a small plate of chips. Is this necessary in a park?

I'm not anti alcohol.but parks are used by children, not always with adult supervision and the idea of individuals boozing near their play is a little disconcerting.

Please give serious contemplation to this application.

Objection 29. The park has already gone down considerably with anti social behaviour and attacks on wildlife, this is unlikely to be improved by the introduction of alcohol. The council needs to take more responsibility to reduce antisocial behaviour and knife crime not add fuel to it

Objection 30. The local shops at Carlton Parade is within a 1-minute walk to the park have extreme drug, alcohol issues and shop lifting is rife this will over spill to the cafe and park.

Application comments:

I have nothing against alcohol licences if issued in the right location and Lopeto Cafe is not the right location in this instance.

The police and local residents have enough to contend with without more additional problems.

Have the local residents been written to in Aynscombe Angle, the properties/cottages in the old Priory gardens buildings that people live in, V22 who rent the old Priory house, Carlton parade, lower part of High Street, Perry Hall Road, Court Road, Old Priory Ave, Gilroy Way, Lower Road. They are all in close proximity and experience anti-social behaviour and the council has a duty to inform them.

V22 have had extreme problems of and calling the police as well.

I cannot express how this licence will have a devastating effect on local residents and our park and wildlife.

Please re consider and stop this.

There needs to be dialogue and discussion between Priory Gardens Wildlife foundation, Friends of Priory gardens, park users, residents, ward councillors, police and wildlife police Team for Bromley.

Objection 31. I wish to object to this proposal. We are having so many problems with ABS in the Park, and having to do shifts to protect the wildlife

I really feel this is going to encourage unsavoury characters into the area.

Objection 32.

I am one of the Orpington Ward Cllrs - to be honest I have a concern here- Today with my husband the current Mayor Cllr Mike Botting we patrolled the Priory park. This is because ducks, geese & swans are being shot with catapults, some have unfortunately been killed by youths frequenting the park . The Police are aware & have made some arrests, but this disgraceful and disgusting behaviour continues. I am aware that drunks already frequent the park, and the purchase of ready alcohol would in my view only exasperate the problem of drinking & anti- social behaviour. Today we had a coffee at the said cafe and although it appears to be clean and well run it's unfortunate in my view that the cafe is situated in the wrong location to serve alcohol. If the application was to be granted the youths carrying the catapults could purchase alcohol which as I said would increase and exasperate the already difficult situation of anti-social behaviour.

CLLR Kim Botting- FRSA
Orpington Ward

Application comments:

SUPPORT

Support 1. No reason in my opinion for objections. Setting is nice and this would be a good addition to the area having another place that can sell alcohol responsibly. Plenty of walkers like to stop for a drink whilst out

Support 2. Lovely idea to have controlled drinking environment in a nice setting. Hopefully will deter antisocial park users later in the day and encourage more people to come to Orpington

Support 3. I am in favour of the Lopeto Cafe's premises License application.

However, because of the cafe's sensitive location in a converted public convenience straddling the Priory Gardens boundary, I feel additional conditions need to be applied.

Principally

1) The outside tables on the 'Park Side' of the cafe (which don't appear to have been included in the submitted premises plan) are situated within the boundary fencing of Priory Gardens.

This seating area should only be in use during Park opening hours.

(As I understand it, Priory Gardens is closed 30 minutes before dusk every day). At this time, customers must move inside the cafe or, if appropriate, to the outside tables on the 'Road Side' of the cafe, which is outside the park boundary. The cafe's 'park side' door must then be securely shut & use restricted to an emergency exit for the Cafe or access on request for police, park officials & emergency services.

2) To assist the Park Authorities in combating problem drinking within Priory Garden, the Cafe Seating area within the park must be roped off & a 'no alcoholic drinks to be taken beyond this point' restriction must be applied.

3) To help protect the local wildfowl in Priory Gardens from unwarranted disturbances, the council's standard 'no drinking or eating outside the premises after 9' restriction should be applied regardless of the proximity of residential properties.

Appendix 3

Revised Timings and Additional Conditions Agreed with Police

From: lopeto cafe
Sent: 25 September 2023 15:28
To: Dandridge Tina
Subject: Re: Proposed conditions

Dear Tina

Thank you very much for your email and I appreciate the advice and guidances.
We would happily accept and commit to the proposal offered by you.

1. The rear door will be closed and locked by 8:00 PM.
2. The CCTV is already in operation and collects and saves footage for the required period of time.
3. A camera already installed and captures full picture of entering customers.
4. The training and review is going on. We make sure to record the training and refresh it within 12 months.
5. We will apply for WAVE training. If you have any further advice please let us know.
6. Currently we have no plan for delivering alcohol but certainly it will be limited to residential or business addresses.
7. Certainly we wont make sales or delivery out of licenced hours.
8. All of sales will be in sealed containers.
9. Will do this immediately.
10. Surely a record of incidence will be kept at premises.
11. Surely a refusal record will be maintained.
12. We will apply this rule.
13. Alcohol will be kept in staff area as you directed.

Best regards

On Fri, 22 Sep 2023, 13:27 , <Tina.Dandridge> wrote:

Thank you for your email – please see below the proposed conditions for your premises licence.
If you are in agreement please forward this email onto the council, stating your agreement.

Opening hours : 0800 – 2200
Alcohol Sales : 1100 - 2130

1. The rear door that has access to the park will be closed and locked at 8pm.
2. A CCTV system will be installed and maintained at the premises providing coverage throughout the premises and recordings shall be stored for a minimum of 28 days. CCTV images shall be retrieved in a digital format and supplied to a Police or Council Officer upon request. At least one person will be on the premises who is trained to operate the CCTV system when licensed activity takes place.

3. At least one CCTV camera shall be installed by the entrance door that enables face, head and shoulders images of a standard that will enable identification of each person entering and leaving the premises.
4. Ensure that all relevant staff within the business are trained in relation to the Licensing Act 2003 and conflict management. Training records shall be available from the premises and made available for inspection by the police or Council officer upon reasonable request. Refresher training will be undertaken every 12 Months (or earlier as necessary).
5. WAVE training will be completed by all staff and a record of this be kept and made available to Police and council officers upon request.
6. Alcohol will be delivered only to residential or to business addresses and shall not be made to public places, such as the park.
7. Deliveries shall take place only during the licensed hours.

8. All off sales will be in sealed containers.

9. Ensure that a Challenge 25 policy is operated at the premises with appropriate signage displayed both inside the premises.
10. Maintain an incident register that that is accessible on the premises. The DPS, or a member of management shall ensure that the details of incidents shall be added to the register within 24 hrs of any incident. The following details shall be recorded:-
 - Date
 - Time
 - Location
 - Persons concerned (or at least a description)
 - Summary of incident
 - Identification of any Emergency Services Personnel who attended
 - Crime or appropriate reference number provided by the Emergency Services that relates to the incident and any linked incidents.
11. Ensure that a refusals record is maintained at the premises and that such a record shall be made immediately available for inspection by the Police or an authorised Officer of the Local Authority.
12. There will be no vertical drinking permitted on the premises or drinking at the bar area.
13. Alcohol will be stored securely in staff only areas on the premises out of reach of the public.

PC Tina Dandridge
Licensing Officer SN BCU

Appendix 4

Street View and Satellite Images of the Premises

Lopeto Café, Priory gardens, Orpington



Satellite Image of Lopeto Café, Priory gardens, Orpington



Report No.
ES20337

London Borough of Bromley

PART ONE - PUBLIC

Decision Maker: LICENSING SUB-COMMITTEE

Date: 20th November 2023

Decision Type: Non-Urgent Non-Executive Non-Key

Title: SUBMISSION OF A TEMPORARY EVENT NOTICE FOR FETHR LOUNGE LTD 145 – 147 CROYDON ROAD BECKENHAM BR3 3RB FOR 30TH – 31ST DECEMBER 2023

Contact Officer: Steve Phillips, Nuisance, ASB, Health & Safety and Licensing Manager
Tel: 020 8313 4659 E-mail: steve.phillips@bromley.gov.uk

Chief Officer: Colin Brand Director: Environment and Community Services

Ward: Kelsey and Eden Park

1. Reason for report

- 1.1 To provide the Licensing Sub-Committee with information supporting them to determine whether to uphold or dismiss objections made against this Temporary Events Notice.

2. **RECOMMENDATIONS**

- 2.1 **The Licensing Sub-Committee are asked to determine this application having taken into account the Council's Statement of Licensing Policy 2021 to 2026 and written and oral representations by the person submitting the TEN and objectors.**

Members can

1. **Grant the temporary event notice as submitted.**
2. **Impose conditions to the TEN from the existing conditions on the premises licence at the venue.**
3. **Uphold the objections made and refuse the TEN by authorising the service of a Counter Notice.**

Impact on Vulnerable Adults and Children

1. Summary of Impact:

When making decisions under the Licensing Act 2003 the Council is required to promote the licensing objectives, one of which is the protection of children from harm.

Corporate Policy

1. Policy Status: Existing Policy:

The Council has adopted a statement of its licensing policy under the Licensing Act 2003 for the period 2021 to 2026.

2. BBB Priority: Children and Young People Excellent Council Quality Environment Safe Bromley Vibrant, Thriving Town Centres Healthy Bromley Regeneration

Financial

1. Cost of proposal: Licensing statutes allow for an appeal to the Magistrates Court against the Council's decision. Should an appeal be made, costs are likely to be incurred but it is not possible to quantify these.
 2. Ongoing costs: Non-Recurring Cost
 3. Budget head/performance centre: Public Protection and Portfolio
 4. Total current budget for this head: £1.6M
 5. Source of funding: 2023/2024
-

Personnel

1. Number of staff (current and additional): 1 Licensing Officer supported by 3.5 FTE admin
 2. If from existing staff resources, number of staff hours: Not Applicable
-

Legal

1. Legal Requirement: Statutory Requirement: The Council is the Licensing Authority for the Licensing Act 2003. This is a Non-Executive function and is delegated to the General Purposes and Licensing Committee. Where representations are received about a licence application, it is referred to the Licensing Sub Committee for a hearing and decision.
 2. Call-in: Not Applicable
-

Procurement

1. Summary of Procurement Implications: Not applicable
-

Property

1. No property implications for this application/licence.
-

Carbon Reduction and Social Value

1. Summary of Carbon Reduction/Sustainability Implications: There are no significant implications.
-

Customer Impact

1. When considering and making a determination on this application Members need to balance the benefits of holding the licence against any adverse effects to the Public, Local Residents and Businesses by considering its impact against the licensing objectives
-

Ward Councillor Views

1. Have Ward Councillors been asked for comments **N/A**
 2. Summary of Ward Councillors' comments: **N/A**
-

Responsible Authorities Views

1. Have Responsible Authorities been asked for comments? **Yes**. The Police and Environmental Health Service were notified about the application by email on 9th November 2023.
2. Summary of Responsible Authorities comments: **Objections** were received from both the Police and Environmental Health Service on the grounds of Public Nuisance.

These objections can be found in **Appendix 2**.

3. COMMENTARY

3.1. Licensing Act 2003.

The Licensing Act 2003 states that any premises requires a licence/certificate issued by the Council (premises licence/club premises certificate) where the following activities occur:-

Provision of regulated entertainment

- a) Plays. (Where the audience exceeds 500 people)
- b) Films.
- c) Indoor sporting events. (Where the audience exceeds 1000 people)
- d) Boxing or wrestling entertainment.
- e) Live music. (subject to the Live Music Act 2013 exemptions)
- f) Recorded music.
- g) Performances of dance. (Where the audience exceeds 500 people)

Provision of late-night refreshment (between 2300hrs and 0500hrs).

Supply of alcohol (on and off sales).

The supply of alcohol by or on behalf of a club to, or to the order of, a member of the club.

The sale by retail of alcohol by or on behalf of a club to a guest of a member of the club for consumption on the premises where the sale takes place.

Licences/Certificates may be issued subject to any terms, conditions or restrictions the Council feels are appropriate to address any or all of the four licensing objectives.

The Council has previously agreed Bromley's Statement of Licensing Policy for the Period 2021 – 2026.

The Licensing Sub-Committee must consider the Statement of Licensing Policy and any Special Policy of Cumulative Impact currently in force when making any decisions in respect of these applications.

Where any premises are not licensed or their licence does not permit any of the above activities or a premises wishes to have an activity outside of the times stated on the existing licence, the Act provides for a person to give a Temporary Event Notice (TEN).

3.2 TENs are subject to certain restrictions including the following;

- a. Standard applications must be made a minimum of 10 clear working days before the event.
- b. Up to 10 late applications (restrictions apply) can be made between 9 and 5 clear working days before an event.
- c. 15 TENs can be submitted for the same premises in a year (Jan to Dec).
- d. A single event can last no longer than 7 days.
- e. There must be a minimum of 24hrs between events.
- f. The maximum number of days in a year that can be permitted by TENs at the same premises is 21.
- g. The maximum number of people that can attend the event is 499.

- 3.3 Where these provisions are met the Council must acknowledge the submission within 48 hours.
- 3.4 Copies of a submission are served on both the Police and the Environmental Health, Public Health Nuisance Team. These Responsible Authorities have 3 working days after the date of receipt to object to a submission of a TEN.
- 3.5 Where an objection is made to a standard TEN the Council must hold a hearing to determine the application within 7 days of the end of the consultation period and at least 24 hours before the start of the period covered by the TEN.
- 3.6 The Licensing Sub Committee must consider both written and verbal representations made at the hearing and have the following options available to them:
1. Grant the temporary event notice as submitted.
 2. Impose conditions to the TEN from the existing conditions on the premises licence at the venue.
 3. Uphold the objections made and refuse the TEN by authorising the service of a Counter Notice.
- 3.7 The 2003 Act provides that the licensing authority can impose conditions to a TEN from the existing conditions on the premises licence or club premises certificate at the venue. The licensing authority can only do so:
- if the police or the EHA have objected to the TEN;
 - if that objection has not been withdrawn;
 - if there is a licence or certificate in relation to at least a part of the premises in respect of which the TEN is given;
 - if the licensing authority considers it appropriate for the promotion of the licensing objectives to impose one or more conditions.

Members' attention is drawn to the following parts of the policy which are relevant to this submission.

Description of the Premises

The premises is a restaurant on the ground floor of a 3 storey building with residential accommodation above. The property is situated on the corner of Croydon Road, Eden Park Avenue and Dunbar Avenue.

A satellite image and street view of the premises can be found in **Appendix 4**.

Licensing History

The premises licence was transferred to the current holder in May 2023. Historically there has been noise nuisance issues with the premises mainly due to there being residential flats directly above.

Since the current licence holders have been running the business there have been a number of noise complaints and a Noise Abatement Notice was served on the premises on 9th August 2023. Since the abatement notice was served a number of noise complaints have been received stating that loud music is being played after 11pm. A copy of current premises licence can be found in **Appendix 3**.

Details of the Application

A TEN has been submitted to hold a leaving party for 100 people on 30th December 2023 until 03:00hrs. The licensable activities include the provision of late night refreshment, the provision of regulated entertainment (a DJ) and the sale of alcohol on the premises. A full copy of the TEN can be found in **Appendix 1**.

Representations

Objections were received from both the Police and Environmental Health Service on the grounds of Public Nuisance. Full details of both objections can be found in **Appendix 2**.

4. IMPACT ON VULNERABLE ADULTS AND CHILDREN

- 4.1 Licensing regimes provide for additional controls through specific permissions to undertake activities. Both the Licensing Act 2003 and Gambling Act 2005 contain licensing objectives which seek to protect particular vulnerable groups. In the case of the Licensing Act 2003 it seeks to protect children from harm whereas the licensing objectives under the Gambling Act 2005 are wider and seek to protect children and vulnerable adults from being harmed or exploited.
- 4.2 Businesses and the Council are required to promote these objectives in the way they operate or make decisions.
- 4.3 Details of applications under both Acts are referred to the appropriate safeguarding teams for comment. The Child Protection Team asked for a Challenge 25 policy condition to be added.

5. TRANSFORMATION / POLICY IMPLICATIONS

- 5.1 Both the Licensing Act 2003 and the Gambling Act 2005 require the Council to prepare, consult on and publish statements of their licensing policy. These must be reviewed at least every 5 years under the Licensing Act and 3 years under the Gambling Act.
- 5.2 Members should make decisions in accordance with these policies but are free to depart from them with good reason.
- 5.3 The current policies are -
 - Statement of Licensing Policy 2021 - 2026
 - Statement of gambling policy 2022 - 2025

6. FINANCIAL IMPLICATIONS

- 6.1 There are rights of Judicial Review and appeal to the Magistrates Court against the decision of the Sub-Committee under both the Licensing and Gambling Acts. If an appeal were to be lodged there are costs associated with defending it. These are difficult to quantify and the Courts can award costs. In the event of a successful appeal we could pay the costs of the appellant as well as our own. Equally if we successfully defended an appeal, it is open to the Court to order our costs to be paid by the appellant.

7. PERSONNEL IMPLICATIONS

- 7.1 Number of staff (current and additional): 1 Licensing Officers supported by 3.5 FTE Administration Staff.
- 7.2 If from existing staff resources, number of staff hours: A licensing application typically takes 7hrs professional officer time and 5hrs administration time.

8. LEGAL IMPLICATIONS

- 8.1 Any Parties involved in a hearing before a Sub-Committee can seek a Judicial Review if the Local Authority has failed to administer the hearing in accordance with proper procedures.
- 8.2 Any Party involved with the hearing before licensing subcommittee can appeal any decision made at that hearing to the magistrate’s court.
- 8.3 The Council has adopted a procedure for the conduct of hearings.

9. PROCUREMENT IMPLICATIONS

There are no procurement implications.

10. EQUALITIES IMPLICATIONS

- 10.1 The Equality Act (2010) requires public bodies to have due regard to the need to:
 - *eliminate unlawful discrimination, harassment, victimization and any other conduct prohibited by the Act.*
 - *advance equality of opportunity between people who share a protected characteristic and people who do not share it; and*
 - *foster good relations between people who share a protected characteristic and people who do not share it.*

10.2 The protected characteristics covered by the Act are age, disability, gender reassignment, marriage and civil partnership, pregnancy and maternity, race, religion or belief, sex, and sexual orientation.

10.3 There is no indication that the proposed recommendations will have a disproportionate impact on any individuals or groups with a shared protected characteristic.

11. ENVIRONMENTAL IMPLICATIONS

There are neutral environmental and carbon reduction implications from the proposals contained in this report.

Non-Applicable Sections:	Property & Procurement
Background Documents: (Access via Contact Officer)	Soft File Computer based records

Appendix 1

Temporary Event Notice

Page 1

Temporary Event Notice

Important new legislation on COVID-19 available [here](#).

Information on the Licensing Act 2003 is available [here](#).

Before completing this form please read the guidance notes.

You may wish to keep a copy of the completed form for your records.

I, the proposed premises user, hereby give notice under section 100 of the Licensing Act 2003 of my proposal to carry on a temporary activity at the premises described below.

Personal Details <i>(Please read note 1)</i>			
Your name			
Title	Forenames	Surname	
Mr	Lirjan	Sufaj	
Previous names <i>(if relevant)</i>			
Have you used any previous names?	Yes	<input type="checkbox"/>	No <input checked="" type="checkbox"/>
Have you used any other previous names?	Yes	<input type="checkbox"/>	No <input type="checkbox"/>
Have you used any other previous names?	Yes	<input type="checkbox"/>	No <input type="checkbox"/>
Your date of birth	14/07/1987		
Your place of birth	Albania		
National Insurance No.	SP537059D		

Page 2

Your current address	
x	
65 Moore Road London SE19 3RB	
Other contact details	
Telephone numbers	
Daytime telephone	07557046691
Evening telephone (optional)	
Mobile telephone (optional)	
Fax number (optional)	
Email address	Fethrmanager@gmail.com
Are you an agent applying on behalf of the applicant? Yes <input type="checkbox"/> No <input checked="" type="checkbox"/>	
Title	
Forenames	
Surname	
Email address	
Main telephone number	
Other telephone number	
<p>Are you</p> <p>An agent that is a business or organisation, including a sole trader <input type="checkbox"/></p> <p>A private individual acting as an agent <input type="checkbox"/></p> <p>Business/organisation name</p> <p>Please confirm who the acknowledgement email and future correspondence should be sent to:</p> <p>The applicant <input type="checkbox"/></p> <p>The agent <input type="checkbox"/></p>	

Page 3 (now hidden)

Alternative address for correspondence (<i>Address for correspondence associated with this application, if different to the previous address</i>)	
Alternative contact details (<i>if applicable</i>)	
Telephone numbers	
Daytime (optional)	
Evening (optional)	
Mobile (optional)	
Fax number (optional)	
Email address (optional)	

The Premises	
Please select the address of the premises where you intend to carry out the licensable activities. If there is no address, please select the street record in the address lookup and supply further details of the location (including ordnance Survey references) (Please read note 2)	
145 - 147 Croydon Road Beckenham BR3 3RB	
Trading name	Fethr Lounge Ltd
Does a premises licence or club premises certificate have effect in relation to the premises (or any part of the premises)? If so, please enter the licence or certificate number below.	
Premises licence number	18/00544/LAPRE
Additional address information	

Page 4

Do you intend to use the whole of the premises at this address (Please read note 3) Yes No

Please give a description and details below

Please describe the nature of the premises below (Please read note 4).

Restaurant/ bar

Please describe the nature of the event below (Please read note 5).

Leaving party

The Licensable Activities		
Please state the licensable activities that you intend to carry on at the premises (Please mark an "X" next to the licensable activities you intend to carry on - either double click with the mouse, or press the space bar in the relevant field) (Please read note 6)		
The sale by retail of alcohol		<input checked="" type="checkbox"/>
The supply of alcohol by or on behalf of a club to, or to the order of, a member of the club		<input type="checkbox"/>
If the licensable activities will include the supply of alcohol, please state whether the supplies will be for consumption on or off the premises, or both (Please read note 12)	On the premises	<input checked="" type="checkbox"/>
	Off the premises	<input type="checkbox"/>
	Both	<input type="checkbox"/>
The provision of regulated entertainment (Please read note 7)		<input checked="" type="checkbox"/>
The provision of late night refreshment		<input checked="" type="checkbox"/>
Select this box if you are giving a late temporary event notice (Please read note 8)		<input type="checkbox"/>

Page 6

Please state the date and times on which you intend to use these premises for licensable activities. (Please read note 8) Please give times in 24 hour clock. e.g. 19:00. (Please read note 9)							
Start Date	30/12/2023	Time	20:00	End Date	31/12/2023	Time	03:00
Please state the maximum number of people at any one time that you intend to allow to be present at the premises during the times when you intend to carry on licensable activities, including any staff, organisers or performers. (Please read note 11)							100

Page 7

State if the licensable activities will include the provision of relevant entertainment. Note:
Relevant Entertainment is defined as any live performance or any live display of nudity etc.

If you are applying for the relevant entertainment activity, please state the times during the event period that you propose to provide the relevant entertainment. (Please read note 13)

Food, drink & DJ

Personal Licence Holders <i>(Please read note 14)</i>	
Do you currently hold a valid personal licence?	Yes <input checked="" type="checkbox"/> No <input type="checkbox"/>
Please provide the details of your personal licence below.	
Issuing licencing authority	Croydon
Licence number	23/0161/LIPERS
Date of issue	17/07/2023
Date of expiry	
Any further relevant details	

Previous Temporary Event Notices you have given <i>(Please read note 15)</i>		
Have you previously given a temporary event notice in respect of any premises for events falling in the same calendar year as the event for which you are now giving this temporary event notice?	Yes <input type="checkbox"/>	No <input checked="" type="checkbox"/>
Please state the number of temporary event notices you have given for events in the same calendar year		
Have you already given a temporary event notice for the same premises in which the event period: a) ends 24 hours or less before; or b) begins 24 hours or less after the event period proposed in this notice?	Yes <input type="checkbox"/>	No <input checked="" type="checkbox"/>

Associates and business colleagues		
Has any associate of yours given a temporary event notice in the same calendar year as the event for which you are now giving a temporary event notice?	Yes <input type="checkbox"/>	No <input checked="" type="checkbox"/>
Please state the total number of temporary event notices your associate(s) have given for events in the same calendar year		
Has any associate of yours already given a temporary event notice for the same premises in which the event period: a) ends 24 hours or less before; or b) begins 4 hours or less after the event period proposed in this notice?	Yes <input type="checkbox"/>	No <input checked="" type="checkbox"/>
Has any person with whom you are in business carrying on licensable activities given a temporary event notice for an event in the same calendar year as the event for which you are now giving a temporary event notice?	Yes <input type="checkbox"/>	No <input checked="" type="checkbox"/>
Please state the total number of temporary event notices your business colleague(s) have given for events in the same calendar year.		
Has any person with whom you are in business carrying on licensable activities already given a temporary event notice for the same premises in which the event period: a) ends 24 hours or less before; or b) begins 24 hours or less after the event period proposed in this notice?	Yes <input type="checkbox"/>	No <input checked="" type="checkbox"/>

Condition *(Please read note 17)*

It is a condition of this temporary event notice that where the relevant licensable activities described in Section 3 above include the supply of alcohol that all such supplies are made by or under the authority of the premises user.

Custom Process Configuration

XML Specific

Application type

Licence Case Type

Licence Status

XML Template

CAPS Reference

Payments request

CallingAppID

CallingAppRef

PaymentSourceCode

Response response

PaymentAuthorisationCode

IncomeManagementReceiptNumber

Originators Reference

CardScheme

CardType

PaymentAmount

ResponseCode

ResponseDescription

Number of payment lines

Process ID From External

Payment 1

Receipt Number

DueDate

PaymentType

Pay Description

XML Description

PaymentDue

Paid

Payment Date

Fund

Reference

Form Calculations

Title Casing

Sentence Casing

UPRN for address lookup

Boolean to "hide" page

Form Reference

User Classification

Email body text

Bank Hols Array calculation

Other Custom Calculations

Calculation for late ten

Calculation for licensable activities

Number of Days TEN Covers

Subject Line for Email Out

Body for Internal Email

Body for External Email

Start Date in XML format

End Date in XML Format

Hours the TEN covers

DOB

Customer Email Acknowledgment

App Day Tel:

App Eve Tel:

App Mobile:

App Fax:

App Email:

Agnt Tel:

Agnt Email:

TEN Notice:

Declarations <i>(Please read note 18)</i>	
The information contained in this form is correct to the best of my knowledge and belief.	
I understand that it is offence:	
To knowingly or recklessly make a false statement in connection with this temporary event notice and that a person is liable on summary conviction for such an offence to a fine of any amount; and	
To permit an unauthorised licensable activity to be carried on at any place an that a person is liable on conviction for any such offence to a fine of any amount, or to imprisonment for a term not exceeding six (6) months, or to both.	
Please tick the box if you agree with the declarations above	<input checked="" type="checkbox"/>
Date	09/11/2023
Name of person signing	Mr Lirjan Sufaj

Appendix 2

Objections

-----Original Message-----

From: White, Graham

Sent: 09 November 2023 16:56

To: Licensing <

Subject: FW: Temporary Event Notice Ref: 23/01419/LATEMP

Licensing,

I have been passed the above TEN to review.

I object to the Notice served on the grounds of the prevention of public Nuisance.

The premises was served a noise abatement notice under the Environmental Protection Act 1990 section 80 on the 9th August 2023. Since then, we have received further complaints from residents in possible breach of the abatement notice.

The Temporary Event Notice is to open till 3am including regulated entertainment and I believe that this will lead to further nuisance to residents.

The premises already holds a premises licence and should operate within the limits of the licence.

Kind regards

Graham White

Statutory Nuisance & Anti-Social Behaviour Enforcement Officer
Statutory Nuisance & Anti-Social Behaviour Team



From: Police Licensing Team,
Bromley Police Station
High Street
Bromley BR1 1ER

To: The Licensing Committee
Civic Centre, Stockwell Close
BR1 3UH
13/11/23

Re: TEN Objection FETHR LOUNGE.

Dear Mr Sufaj

On Thursday 9th November 2023 Police received a TEN application ref 23/01419/LATEMP which relates to FETHR LOUNGE, 145 – 147 Croydon Road, Beckenham, BR3 3RB. The TEN requested that on Saturday the 30TH December 2023 the following licensable activities will take place between the hours of 2000 hrs and 0300hrs: Sale of Alcohol on the premises, the provision of regulated entertainment and late night refreshment. The event is described as a leaving party with food, drink and a DJ for 100 people.

I spoke to you on the telephone and you confirmed that the TEN was a party booking and that you would have SIA on duty however the number of SIA was not confirmed.

I am satisfied that allowing this event to go ahead would undermine the Licensing objective of Public Nuisance. I am aware that a noise abatement notice has been served on the premises by the Council and despite this there continues to be complaints about noise from local residents.

Yours Sincerely,

PC Tina Dandridge 3560SN

Bromley Police Licensing Team

Appendix 3

Current Licence



LICENSING ACT 2003

Premises Licence London Borough of Bromley

Premises licence number

18/00544/LAPRE

S Phillips

Steve Phillips
Nuisance, ASB, Health, Safety and Licensing Manager

Licence Granted 24th November 2005

Issue Number

009

This licence consists of 9 pages (Including Licence Summary)

Part 1 – Premises Details

Postal address of premises, or if none, ordnance survey map reference or description

Fethr Lounge
145 – 147 Croydon Road
Beckenham
Kent
BR3 3RB

Where the licence is time limited the dates

Not applicable.

Licensable activities authorised by the licence

Sale or Supply of Alcohol
Late Night Refreshment

Where the licence authorises supplies of alcohol whether these are on and/or off sales

On Sales Only (Subject to Mandatory Conditions)



The opening hours of the premises

Hours open to the public on Monday-Saturday from 10:00 to 00:30

Hours open to the public on Sunday from 12:00 to 00:00

The times the licence authorises the carrying out of licensable activities

Sale or Supply of Alcohol on Monday-Saturday from 10:00 to 00:00

Sale or Supply of Alcohol on Sunday from 12:00 to 23:30

Late Night Refreshment on Every Day same as above

Part 2

Name, (registered) address, telephone number and email (where relevant) of holder of premises licence

Fethr Lounge Ltd
of
145 - 147 Croydon Road
Beckenham
BR3 3RB

Registered number of holder, for example company number, charity number (where applicable)

Registered under 14828163 Limited Company

Name, address and telephone number of designated premises supervisor where the premises licence authorises for the supply of alcohol

Full Name: Mr Lirjan Sufaj
Address:

Personal licence number and issuing authority of personal licence held by designated premises supervisor where the premises licence authorises for the supply of alcohol

DPS Licence Ref:



Mandatory Conditions

1. Supply of Alcohol:

(1). No supply of alcohol may be made at a time when no designated premises supervisor has been specified in the licence or at a time when the designated premises supervisor does not hold a personal licence or the personal licence has been suspended.

(2). Every sale of alcohol under the premises licence must be authorised by a personal licence holder.

2. Irresponsible Promotions:

(1). The responsible person must ensure that staff on relevant premises do not carry out, arrange or participate in any irresponsible promotions in relation to the premises.

(2). In this paragraph, an irresponsible promotion means any one or more of the following activities, or substantially similar activities, carried on for the purpose of encouraging the sale or supply of alcohol for consumption on the premises—

(a) games or other activities which require or encourage, or are designed to require or encourage, individuals to— .

(i) drink a quantity of alcohol within a time limit (other than to drink alcohol sold or supplied on the premises before the cessation of the period in which the responsible person is authorised to sell or supply alcohol), or .

(ii) drink as much alcohol as possible (whether within a time limit or otherwise);

(b) provision of unlimited or unspecified quantities of alcohol free or for a fixed or discounted fee to the public or to a group defined by a particular characteristic in a manner which carries a significant risk of undermining a licensing objective;

(c) provision of free or discounted alcohol or any other thing as a prize to encourage or reward the purchase and consumption of alcohol over a period of 24 hours or less in a manner which carries a significant risk of undermining a licensing objective;

(d) selling or supplying alcohol in association with promotional posters or flyers on, or in the vicinity of, the premises which can reasonably be considered to condone, encourage or glamorise anti-social behaviour or to refer to the effects of drunkenness in any favourable manner;

(e) dispensing alcohol directly by one person into the mouth of another (other than where that other person is unable to drink without assistance by reason of disability).



3. Free Potable Water

(1). The responsible person must ensure that free potable water is provided on request to customers where it is reasonably available.

4. Age Verification:

(1). The premises licence holder or club premises certificate holder must ensure that an age verification policy is adopted in respect of the premises in relation to the sale or supply of alcohol.

(2). The designated premises supervisor in relation to the premises licence must ensure that the supply of alcohol at the premises is carried on in accordance with the age verification policy.

(3). The policy must require individuals who appear to the responsible person to be under 18 years of age (or such older age as may be specified in the policy) to produce on request, before being served alcohol, identification bearing their photograph, date of birth and either—

- (a) a holographic mark, or
- (b) an ultraviolet feature.

5. Minimum Measures:

(1). The responsible person must ensure that —

(a) where any of the following alcoholic drinks is sold or supplied for consumption on the premises (other than alcoholic drinks sold or supplied having been made up in advance ready for sale or supply in a securely closed container) it is available to customers in the following measures— .

- (i) beer or cider: ½ pint; .
- (ii) gin, rum, vodka or whisky: 25 ml or 35 ml; and .
- (iii) still wine in a glass: 125 ml; .

(b) these measures are displayed in a menu, price list or other printed material which is available to customers on the premises; and .

(c) where a customer does not in relation to a sale of alcohol specify the quantity of alcohol to be sold, the customer is made aware that these measures are available.

6. Permitted Price:

(1). A relevant person shall ensure that no alcohol is sold or supplied for consumption on or off the premises for a price which is less than the permitted price.

(2). For the purposes of the condition set out in paragraph 1 -

- (a) "duty" is to be construed in accordance with the Alcoholic Liquor Duties Act 1979;
- (b) "permitted price" is the price found by applying the formula -



$$P = D + (D \times V)$$

where -

- (i) P is the permitted price,
- (ii) D is the amount of duty chargeable in relation to the alcohol as if the duty were charged on the date of the sale or supply of the alcohol, and
- (iii) V is the rate of value added tax chargeable in relation to the alcohol as if the value added tax were charged on the date of the sale or supply of the alcohol;

(c) "relevant person" means, in relation to premises in respect of which there is in force a premises licence -

- (i) the holder of the premises licence,
- (ii) the designated premises supervisor (if any) in respect of such a licence, or
- (iii) the personal licence holder who makes or authorises a supply of alcohol under such a licence;

(d) "relevant person" means, in relation to premises in respect of which there is in force a club premises certificate, any member or officer of the club present on the premises in a capacity which enables the member or officer to prevent the supply in question; and

(e) "value added tax" means value added tax charged in accordance with the Value Added Tax Act 1994.

(3). Where the permitted price given by Paragraph (b) of paragraph 2 would (apart from this paragraph) not be a whole number of pennies, the price given by that sub-paragraph shall be taken to be the price actually given by that sub-paragraph rounded up to the nearest penny.

(4). (1). Sub-paragraph (2) applies where the permitted price given by Paragraph (b) of paragraph 2 on a day ("the first day") would be different from the permitted price on the next day ("the second day") as a result of a change to the rate of duty or value added tax.

(2). The permitted price which would apply on the first day applies to sales or supplies of alcohol which take place before the expiry of the period of 14 days beginning on the second day.



7. Films:

(1). The admission of children must be restricted in accordance with the recommendations laid down by the British Board of Film Classification.

OR

(2). In circumstances where the licensing authority has reclassified a film. Then access of children should be restricted to meet this reclassification standard.

Note:- "Children" means any person under 18 years of age.

8. Door Supervision:

- (1). Any individual employed at the premises as a door supervisor must
- (a) be authorised to carry out that activity by a licence granted under the Private Security Industry Act 2001; or
 - (b) be entitled to carry out that activity by virtue of section 4 of that Act.

Conditions consistent with the Operating Schedule

9. Alcohol and food may be consumed during the first 30 minutes after the end of the above periods, provided the alcohol was sold for consumption as an ancillary to their meals

10. Alcohol may be sold or supplied:

- (a) On weekdays, other than Christmas Day, Good Friday or New Year's Eve from 10.00 . to 00.00.
- (b) On Sundays, other than Christmas Day or New Year's Eve, and on Good Friday: 1200 to 23.30.
- (c) On Christmas Day: 1200 to 23.30.
- (d) On New Year's Eve, except on a Sunday, 11.00 to 00.00.
- (e) On New Year's Eve on a Sunday, 1200 to 23.30 .
- (f) On New Year's Eve from the end of permitted hours on New Year's Eve to the start of permitted hours on the following day (or, if there are no permitted hours on the following day, midnight on 31st December).

11. Alcohol shall not be sold :

- (a) unless the premises have been structurally and bona fide used, or intended to be used for the purpose of habitually providing the customary main meal at midday or in the evening, or both for the accommodation of persons frequenting the premises;
- (b) on the premises otherwise than to persons taking table meals there and for consumption by such a person as an ancillary to his meal.
- (c) unless suitable beverages other than alcohol (including drinking water) are equally available for consumption with or otherwise as an ancillary to meals served in the premises.



12. Entertainment may be provided by the reproduction of wireless (including television) broadcasts or of programmes included in any other service (within the meaning of the Broadcasting Act 1990)

or

Entertainment by way of music and singing only which is provided solely by the reproduction of recorded sound, the purpose of which is to provide background entertainment only

or

The incidental performance of live music. This is where it is incidental to another activity which itself is not entertainment or provision of entertainment facilities

Conditions attached after a hearing by the Licensing Authority

Not Applicable

Plans

Held by the Licensing Authority Ref Number: **18/00544/LAPRE**

Dated – **8th August 2018**

**LICENSING ACT 2003****Premises Licence Summary****Premises licence number****18/00544/LAPRE**

Steve Phillips
Nuisance, ASB, Health, Safety and Licensing Manager

Licence Granted 24th November 2005

Issue Number

009This licence summary consists of **2** pages**Premises Details****Postal address of premises, or if none, ordnance survey map reference or description**

Fethr Lounge
145 – 147 Croydon Road
Beckenham
Kent
BR3 3RB

Where the licence is time limited the dates

Not applicable.

Licensable activities authorised by the licence

Sale or Supply of Alcohol
Late Night Refreshment

The opening hours of the premises

Hours open to the public on Monday-Saturday from 10:00 to 00:30
Hours open to the public on Sunday from 12:00 to 00:00



Where the licence authorises supplies of alcohol whether these are on and/or off sales

On Sales Only (Subject to Mandatory Conditions)

The times the licence authorises the carrying out of licensable activities

Sale or Supply of Alcohol on Monday-Saturday from 10:00 to 00:00

Sale or Supply of Alcohol on Sunday from 12:00 to 23:30

Late Night Refreshment on Every Day same as above

Name, (registered) address of holder of premises licence

Fethr Lounge Ltd
of
145 - 147 Croydon Road
Beckenham
BR3 3RB

Registered number of holder, for example company number, charity number (where applicable)

Registered under 14828163 Limited Company

Name of designated premises supervisor where the premises licence authorises for the supply of alcohol

Full Name: Mr Lirjan Sufaj

State whether access to the premises by children is restricted or prohibited

Not applicable

Appendix 4

Street View and Satellite Images of the Premises

Street view of Fethr Lounge 145 – 147 Croydon Road, Beckenham BR3 3RB



Satellite Image of Fethr Lounge 145 – 147 Croydon Road, Beckenham BR3 3RB



Close up Satellite Image of Fethr Lounge 145 – 147 Croydon Road, Beckenham BR3 3RB

